

Amphenol 安费诺 123GB-0799-0 PDF

Amphenol

深圳创唯电子有限公司

<http://www.amphenol-connect.com>

Amphenol®

TERRAPIN

Miniature Rugged Connector Series



TERRAPIN

Miniature Rugged Connector Series

Intended for harsh environment applications and used extensively in soldier communications, Amphenol Terrapin is a miniature series of circular push-pull connectors. Within a rugged shell design Terrapin offers superior EMC performance and high environmental sealing to IP68. Resilient in severe battlefield situations the RoHS compliant black-silver plating is both low-lustre and corrosion resistant. Featuring an optional locking mechanism, multiple shell sizes with up to 37 contacts and suitability for overmoulding, Terrapin is the preferred choice for miniature connectors in military and other harsh environment applications.

Terrapin shells are machined from brass giving an increased number of mating cycles and higher degree of robustness over traditional aluminium connectors. Five different keying options are available to prevent mis-mating; N, A, B, C and D. Standard plating is non-reflective black-silver, alternative plating finishes are available upon request.

Terrapin is available in two different styles of mating; either Snatch, being a break-away connector with no moving parts, or Latch, which has an additional coupling ring allowing connections to be locked together. The same plug can be mated to either Snatch or Latch receptacles. Both styles of product are waterproof to IP68 in both their mated and unmated conditions.

Amphenol offer a full range of cable harness solutions with standard or customised overmoulding. Alternatively, for field termination, both integral and threaded backshell

connectors can be terminated with screen retention straps and heatshrink boots giving full 360° screening.

The customised design specification of Terrapin lends itself to a variety of applications. Originally designed for soldier mounted applications such as Radios, Headsets and GPS units, Terrapin is also suitable for Gigabit Ethernet and USB 2.0 and therefore widely used on Computer Systems, LAN Switches and Routers. The high degree of sealing offered by Terrapin makes it perfect for Unmanned Ground Sensors and Surveillance equipment. Whatever the application, Terrapin offers space savings and improved durability over traditional interconnect products.

Contents

Terrapin terminology	4
Terrapin mating options	4
Terrapin PART NUMBERING	5
Terrapin performance information	6
Terrapin insert availability	7

Plugs

Table of styles	8
76A Rear Mount Jam Nut Plug	9
67A Front Mount Jam Nut Plug	10
06K Inline Plug Integral Backshell	11
06T Inline Plug Threaded Backshell	12
76T Rear Mount Jam Nut Plug (Screw On Backshell)	13

Receptacles

Table of styles	14
01K Inline Receptacle, Integral Backshell	15
L1K Inline Latching Receptacle, Integral Backshell	16
01T Inline Receptacle, Threaded Backshell	17
L1T Inline Latching Receptacle, Threaded Backshell	18
07A Rear Mount Jam Nut Receptacle	19
71A Front Mount Receptacle, Threaded	20

Accessories

390-5057 Metal Dust Cap Assembly for Plugs	21
390-5056 Metal Dust Cap Assembly for Receptacles	22
390-5064 Rubber Dust Cap Assembly for Plugs	23
390-5063 Rubber Dust Cap Assembly for Receptacles	24
Accessories	25
Overmoulded cable harnesses	25

Terrapin terminology

L1T



Body

Backshell

Crimp ferrule

L1K



Coupling ring

Integral backshell

01K



Integral backshell for
direct screen termination

Terrapin mating options

Chassis Mount Plug SCE2-B-76A

The same Chassis Mount Plug will mate with both Snatch and Latch Receptacles



Snatch Inline Receptacle SCE2-B-01K



Latch Inline Receptacle SCE2-B-L1K





Terrapin part numbering

Example: **SCE2-B-76A06-07SN-002** | (985) for optional grounding spring in L1K and L1T | (981) castellated panel nut

SCE2-	B-	XXX	XX-	XX	-X	X-	XXX
Series identifier	Plating finish B = Black Silver (RoHS)	Style Plugs 76A 67A 06K 06T 76T Receptacles 01K L1K 01T L1T 07A 71A	Shell size and	number of contacts 06-07 07-10A 07-12 07-14 08-19 09-26 10-37 (See page 7)	Contact style P = Pins S = Sockets	Key orientation N = Normal A B C D (See diagrams below)	Variant code 001 PC Tails 002 Solder Buckets 003 Backshell

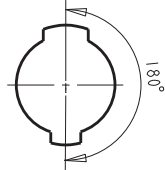
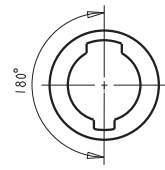
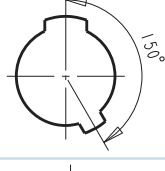
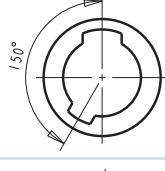
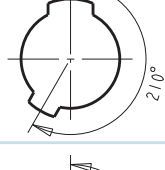
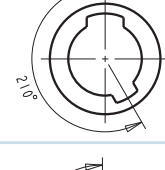
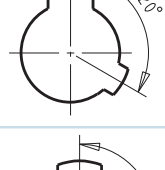
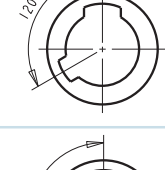
Terrapin plug and receptacle keyway orientation

Keyway orientation letter	PLUG keyway orientation	RECEPTACLE keyway orientation
N		
A		
B		
C		
D		

Terrapin performance information

Test/parameter	Description
Electrical	
Current Rating	23 AWG contacts: 3A d.c.
	20 AWG contacts: 7.5A d.c.
Shell to Shell Continuity	10mΩ max (screened)
	200mΩ max (unscreened)
Contact Resistance	Size 20 and 23 contacts: 5mΩ initial
	10mΩ maximum
Insulation Resistance	5000MΩ minimum
Working Voltage	AC (RMS) 400V
Dielectric Withstanding Voltage	2mA maximum leakage
Technical	
Mating Durability	2000+ cycles
Backshell Overtorque	25 lb.f.in.
Panel Nut Overtorque	30 lb.f.in.
Non-magnetic	Yes
Environmental	
Operating Temperature Range	-55°C to +125°C
Temperature Endurance	250 hours +125°C
Sealing (mated and unmated)	IP68, 1 hour at 2 metres*
Air Leakage	Less than 1 cc per hour
Salt Spray	1000 hours
Altitude Immersion	70,000 Feet
RoHS Compliant	Yes
Suitable for RoHS compliant Soldering	Yes

*Contact the factory if greater depth/duration of sealing is required

Terrapin insert availability View shown for reference / View from rear of plug

Terrapin insert availability

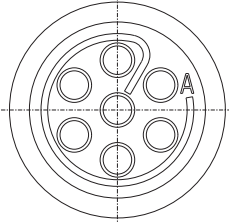
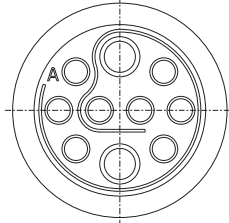
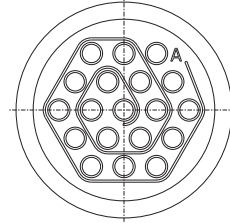
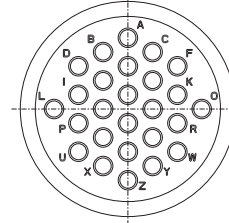
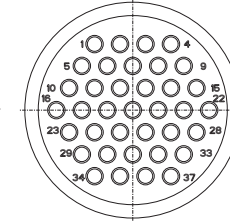
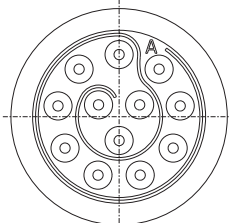
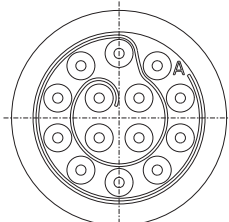
Shell size				
06	07	08	09	10
06-07	07-10A	08-19	09-26	10-37
				
	07-12			
				
	07-14			
				

Plugs – table of styles

SCE2-X-76A

Page 9

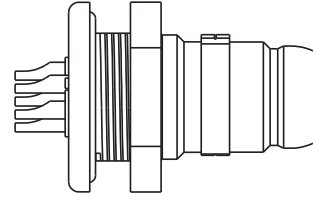

SCE2-X-67A

Page 10

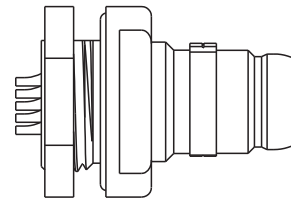

SCE2-X-06K

Page 11

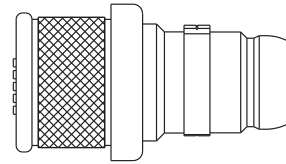

SCE2-X-06T

Page 12

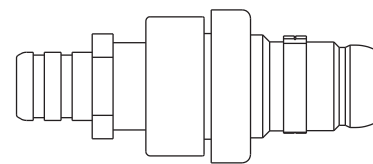

SCE2-X-76T

Page 13

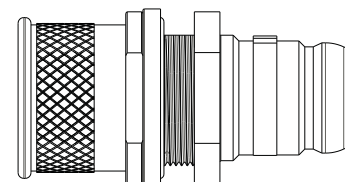

Plug

SCE2-X-76AXX-XXSX-XXX

■ Rear Mount Jam Nut Plug



Plug

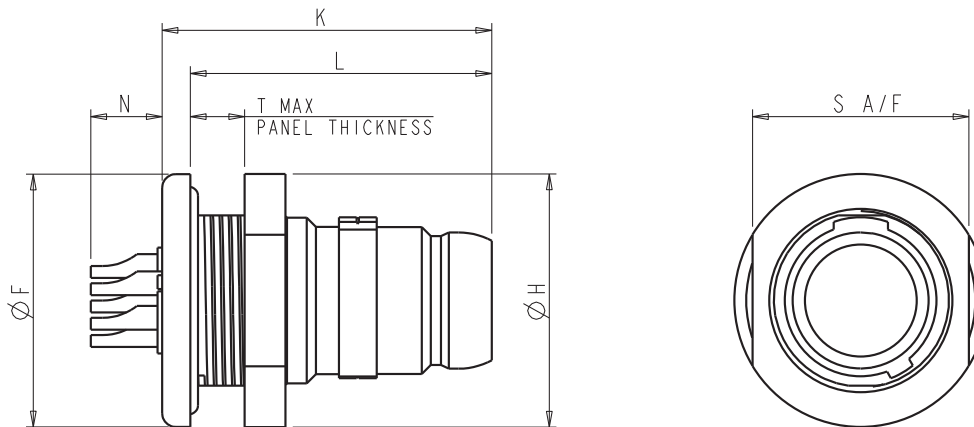

SOLDER BUCKET TYPE (-002)

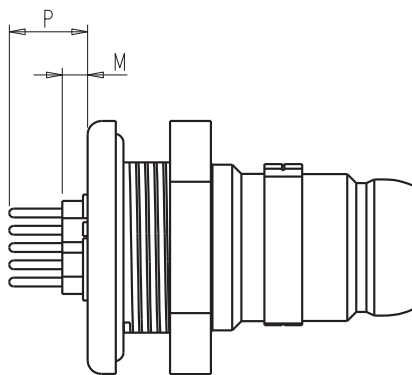

PC TAIL TYPE (-001)

Shell Size	ØF	ØH	K	L	M	N	P	S A/F	T Max
Size 06	.550 (13.97)	.550 (13.97)	.716 (18.19)	.655 (16.64)	.055 (1.40)	.155 (3.94)	.170 (4.32)	.470 (11.94)	.118 (3.00)
Size 07	.620 (15.75)	.600 (15.24)	.716 (18.19)	.655 (16.64)	.055 (1.40)	.155 (3.94)	.170 (4.32)	.510 (12.95)	.118 (3.00)
Size 08	.760 (19.30)	.760 (19.30)	.716 (18.19)	.655 (16.64)	.055 (1.40)	.155 (3.94)	.170 (4.32)	.706 (17.93)	.118 (3.00)
Size 09	.890 (22.61)	.830 (21.08)	.802 (20.37)	.725 (18.42)	N/A	.085 (2.16)	.100 (2.54)	.745 (18.92)	.118 (3.00)
Size 10	.930 (20.62)	.900 (22.86)	.802 (20.37)	.725 (18.42)	N/A	.085 (2.16)	.100 (2.54)	.808 (20.52)	.125 (3.18)

All dimensions are in inches (mm shown in brackets) and are for reference only. Figure enlarged scale.

Plug

SCE2-X-**67**AXX-XXSX-XXX

■ Front Mount Jam Nut Plug



Plug

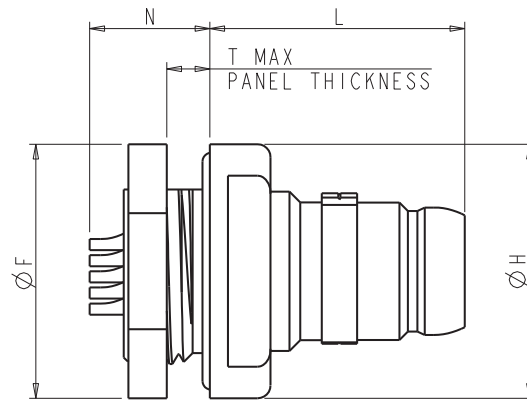

SOLDER BUCKET TYPE (-002)

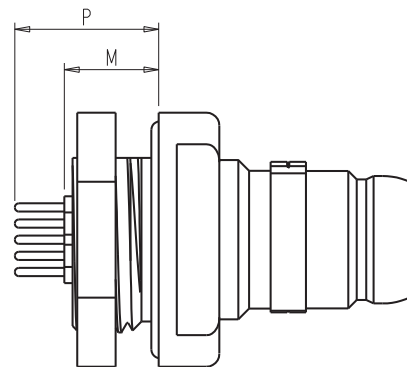
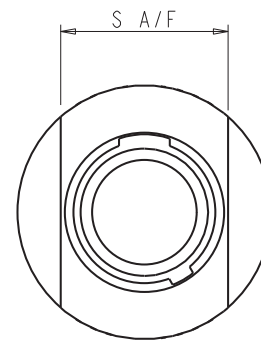

PC TAIL TYPE (-001)

Shell Size	ØF	ØH	L	M	N	P	S A/F	T Max
Size 06	.590 (14.99)	.590 (14.99)	.592 (13.04)	.324 (8.23)	.279 (7.09)	.424 (10.78)	.525 (13.34)	.100 (2.54)
Size 07	.620 (15.75)	.620 (15.75)	.592 (13.04)	.324 (8.23)	.279 (7.09)	.424 (10.78)	.685 (17.40)	.100 (2.54)
Size 08	.760 (19.30)	.760 (19.30)	.592 (13.04)	.324 (8.23)	.279 (7.09)	.424 (10.78)	.825 (20.96)	.100 (2.54)
Size 09	.890 (22.61)	.890 (22.61)	.662 (16.82)	.254 (6.45)	.209 (5.31)	.354 (8.99)	.955 (24.26)	.100 (2.54)
Size 10	.930 (23.62)	.930 (23.62)	.662 (16.82)	.254 (6.45)	.209 (5.31)	.354 (8.99)	.995 (25.27)	.100 (2.54)

All dimensions are in inches (mm shown in brackets) and are for reference only. Figure enlarged scale.

Plug

SCE2-X-06KXX-XXSX

■ Inline Plug Integral Backshell



Plug

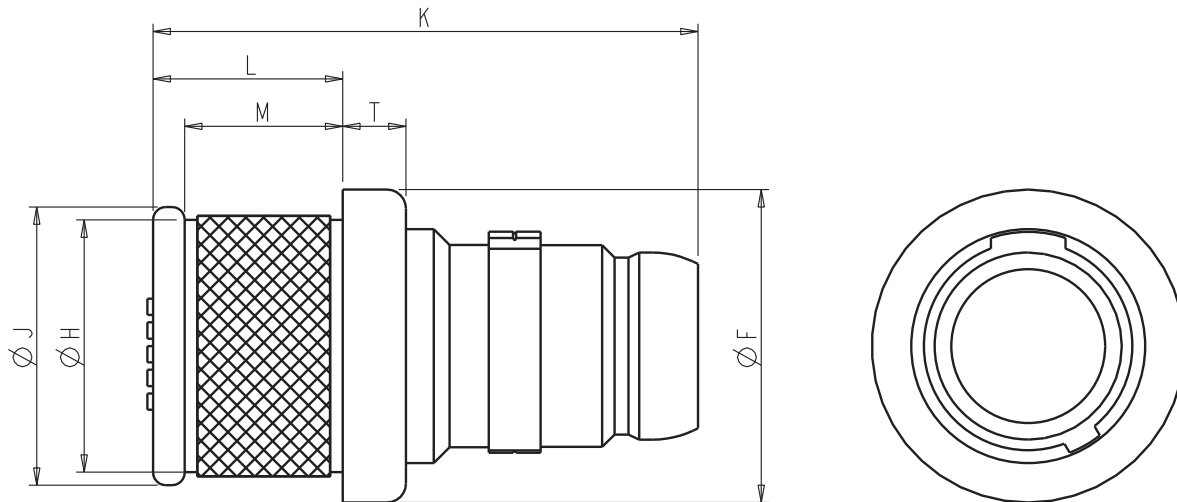

Shell Size	ØF	ØH	ØJ	K	L	M	T
Size 06	.495 (12.57)	.412 (10.46)	.440 (11.18)	.862 (21.89)	.300 (7.62)	.250 (6.35)	.100 (2.54)
Size 07	.575 (14.61)	.460 (11.68)	.505 (12.83)	.862 (21.89)	.300 (7.62)	.250 (6.35)	.100 (2.54)
Size 08	.650 (16.51)	.593 (15.06)	.620 (15.75)	.862 (21.89)	.300 (7.62)	.250 (6.35)	.100 (2.54)
Size 09	.725 (18.42)	.651 (16.54)	.690 (17.53)	.932 (23.67)	.300 (7.62)	.250 (6.35)	.100 (2.54)
Size 10	.800 (20.32)	.721 (18.31)	.760 (19.30)	.932 (23.67)	.300 (7.62)	.250 (6.35)	.100 (2.54)

All dimensions are in inches (mm shown in brackets) and are for reference only. Figure enlarged scale.

Plug

SCE2-X-06TXX-XXSX-003

■ Inline Plug Threaded Backshell



Plug

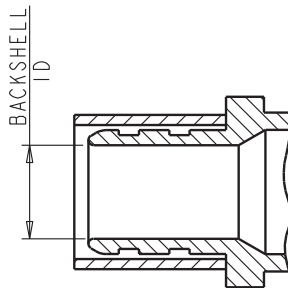
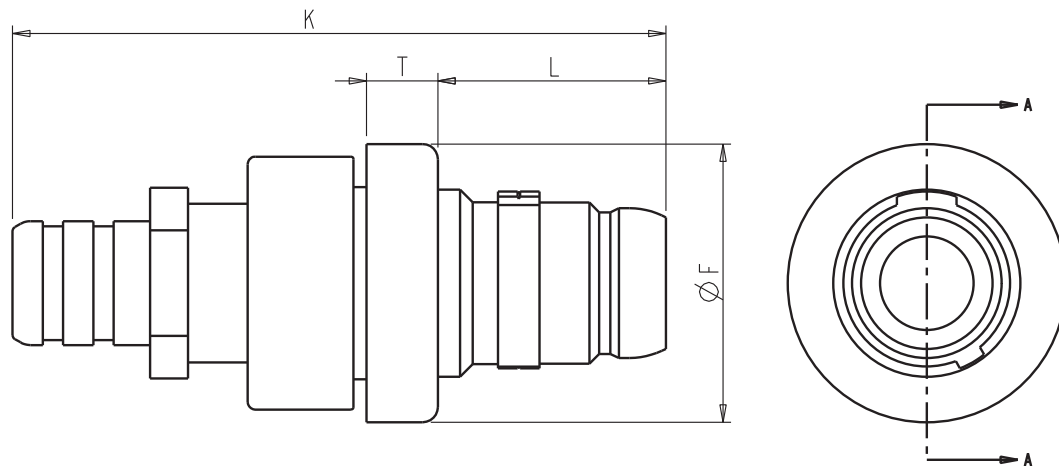

SECTION A-A
-003 ACCESSORY

Shell Size	ØF	K	L	T	Backshell ID
					-003
Size 06	.550 (13.97)	1.292 (32.82)	.451 (11.46)	.141 (3.58)	.185 (4.70)
Size 07	.630 (16.00)	1.292 (32.82)	.451 (11.46)	.141 (3.58)	.265 (6.73)
Size 08	.705 (17.91)	1.292 (32.82)	.451 (11.46)	.141 (3.58)	.345 (8.76)
Size 09	.780 (19.81)	1.362 (34.60)	.521 (13.23)	.141 (3.58)	.425 (10.80)
Size 10	.855 (21.72)	1.362 (34.60)	.521 (13.23)	.141 (3.58)	.505 (12.83)

All dimensions are in inches (mm shown in brackets) and are for reference only. Figure enlarged scale.

Plug

SCE2-X-**76TXX-XXSX-XXX**

- Rear Mount Jam Nut Plug (Screw On Backshell)



Plug

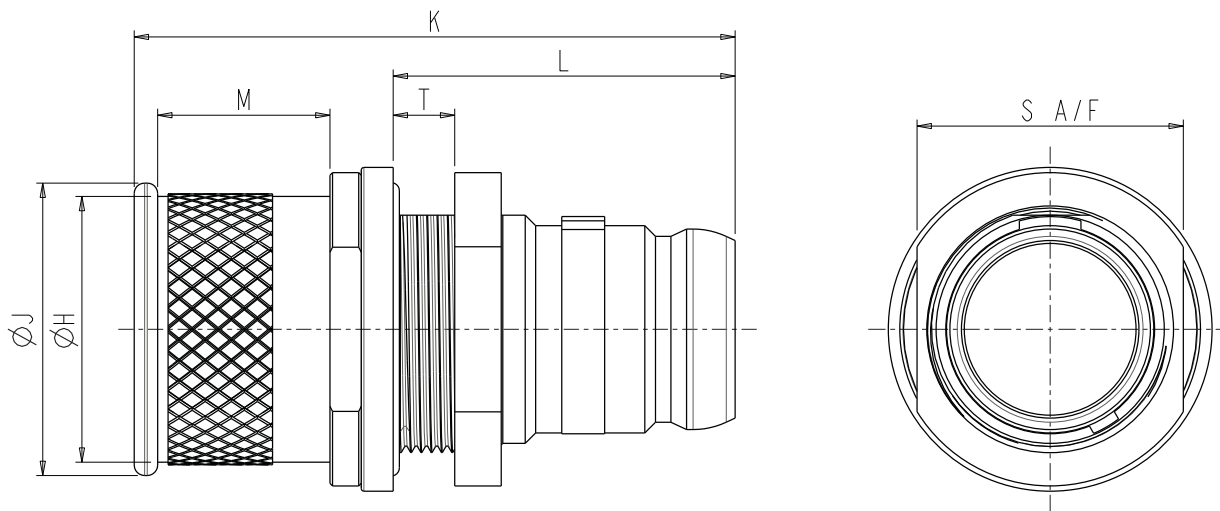

Shell Size	ØH	ØJ	K	L	M	S A/F	T Max
Size 06	.460 (11.68)	.490 (12.45)	1.150 (29.21)	.655 (16.64)	.330 (8.38)	.470 (11.94)	.125 (3.18)
Size 07	.600 (15.24)	.645 (16.83)	1.150 (29.21)	.655 (16.64)	.330 (8.38)	.510 (12.95)	.125 (3.18)
Size 08	.730 (18.54)	.770 (19.56)	1.150 (29.21)	.655 (16.64)	.330 (8.38)	.706 (17.93)	.125 (3.18)
Size 09	.790 (20.07)	.830 (21.08)	1.220 (30.99)	.725 (18.42)	.330 (8.38)	.745 (18.92)	.125 (3.18)
Size 10	.860 (21.84)	.900 (22.86)	1.220 (30.99)	.725 (18.42)	.330 (8.38)	.808 (20.52)	.125 (3.18)

All dimensions are in inches (mm shown in brackets) and are for reference only. Figure enlarged scale.

Receptacles – table of styles

SCE2-X-01K

Page 15

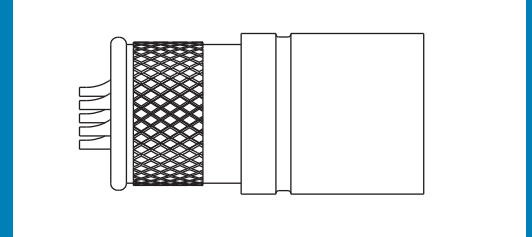

SCE2-X-L1K

Page 16

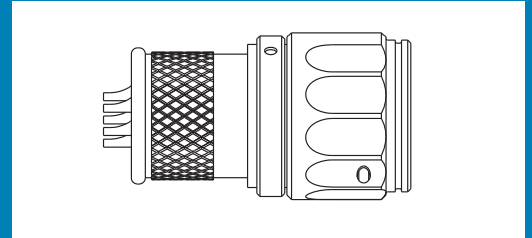

SCE2-X-01T

Page 17

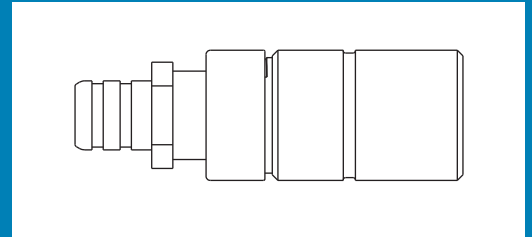

SCE2-X-L1T

Page 18

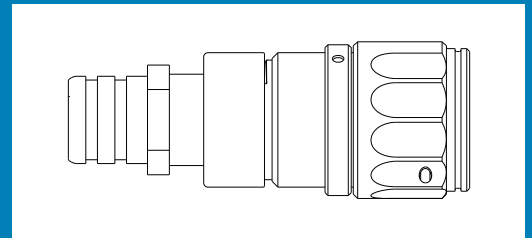

SCE2-X-07A

Page 19

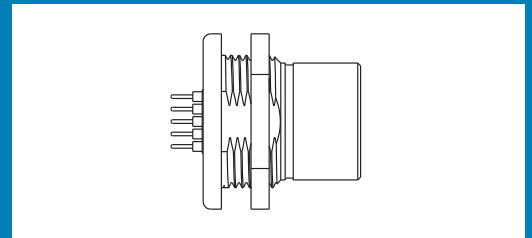

SCE2-X-71A

Page 20

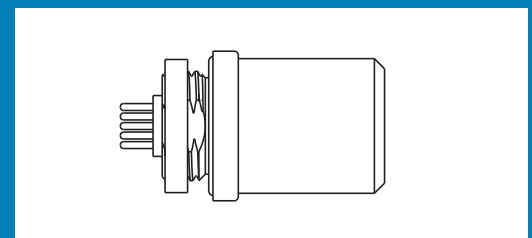

Receptacle

SCE2-X-01KXX-XXPX

■ Inline Receptacle, Integral Backshell



Receptacle

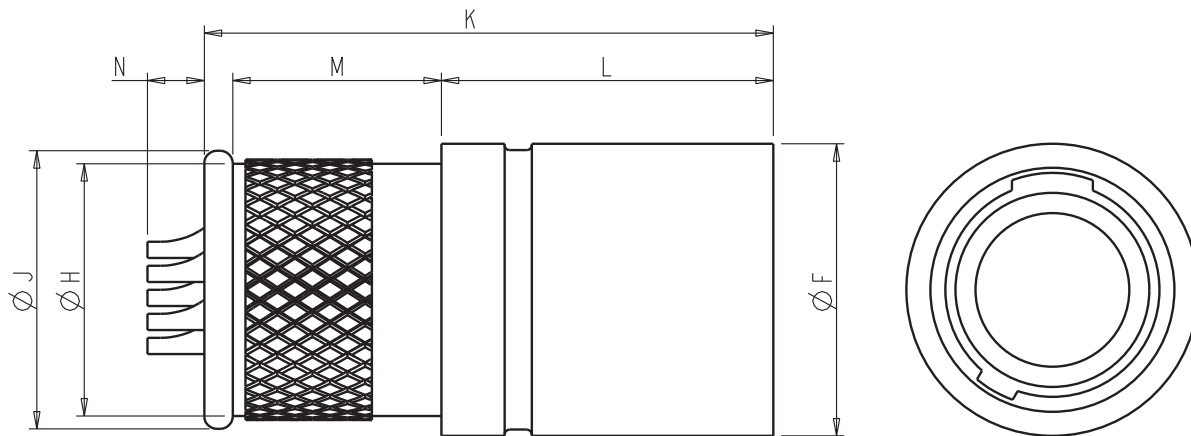

Shell Size	ØF	ØH	ØJ	K	L	M	N
Size 06	.462 (11.73)	.399 (10.13)	.440 (11.18)	.900 (22.86)	.525 (13.34)	.330 (8.38)	.090 (2.29)
Size 07	.575 (14.61)	.460 (11.68)	.505 (12.83)	.900 (22.86)	.525 (13.34)	.330 (8.38)	.090 (2.29)
Size 08	.620 (15.75)	.581 (14.76)	.620 (15.75)	.900 (22.86)	.525 (13.34)	.330 (8.38)	.090 (2.29)
Size 09	.691 (17.55)	.651 (16.54)	.690 (17.53)	.970 (24.64)	.525 (13.34)	.400 (10.16)	.020 (0.51)
Size 10	.761 (19.33)	.721 (18.31)	.760 (19.30)	.970 (24.64)	.525 (13.34)	.400 (10.16)	.020 (0.51)

All dimensions are in inches (mm shown in brackets) and are for reference only. Figure enlarged scale.

Receptacle

SCE2-X-L1KXX-XXPX

- Inline Latching Receptacle, Integral Backshell

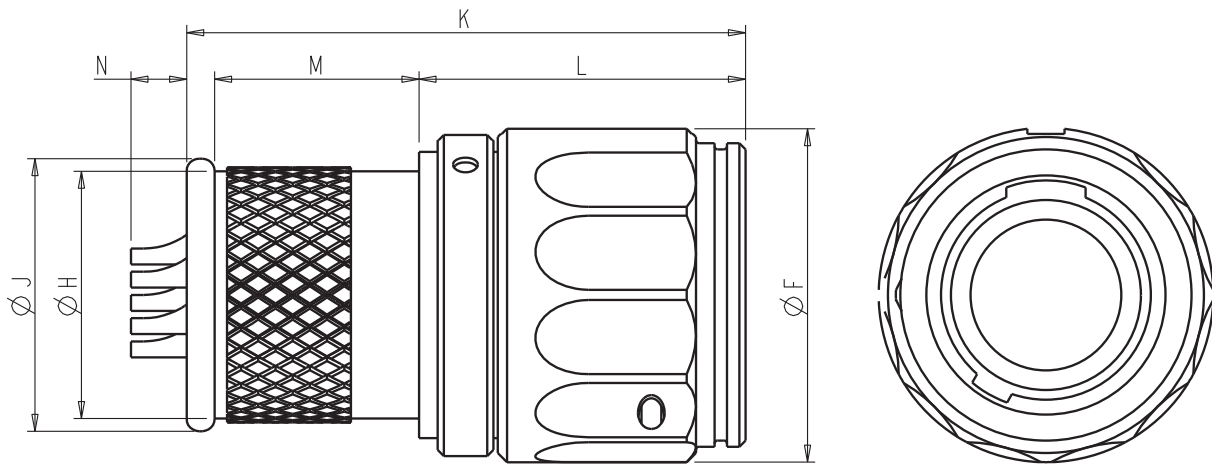

Shell Size	ØF	ØH	ØJ	K	L	M	N
Size 06	.540 (13.75)	.399 (10.14)	.440 (11.18)	.902 (22.91)	.527 (13.39)	.330 (8.38)	.090 (2.29)
Size 07	.610 (15.50)	.447 (11.35)	.505 (12.83)	.902 (22.91)	.527 (13.39)	.330 (8.38)	.090 (2.29)
Size 08	.699 (17.75)	.581 (14.75)	.620 (15.75)	.902 (22.91)	.527 (13.39)	.330 (8.38)	.090 (2.29)
Size 09	.770 (19.56)	.651 (16.54)	.690 (17.53)	.972 (24.69)	.527 (13.39)	.400 (10.16)	.090 (2.29)
Size 10	.840 (21.34)	.721 (18.31)	.760 (19.30)	.972 (24.69)	.527 (13.39)	.400 (10.16)	.090 (2.29)

All dimensions are in inches (mm shown in brackets) and are for reference only. Figure enlarged scale.

Receptacle

SCE2-X-01TXX-XXPX-003

- Inline Receptacle, Threaded Backshell



Receptacle

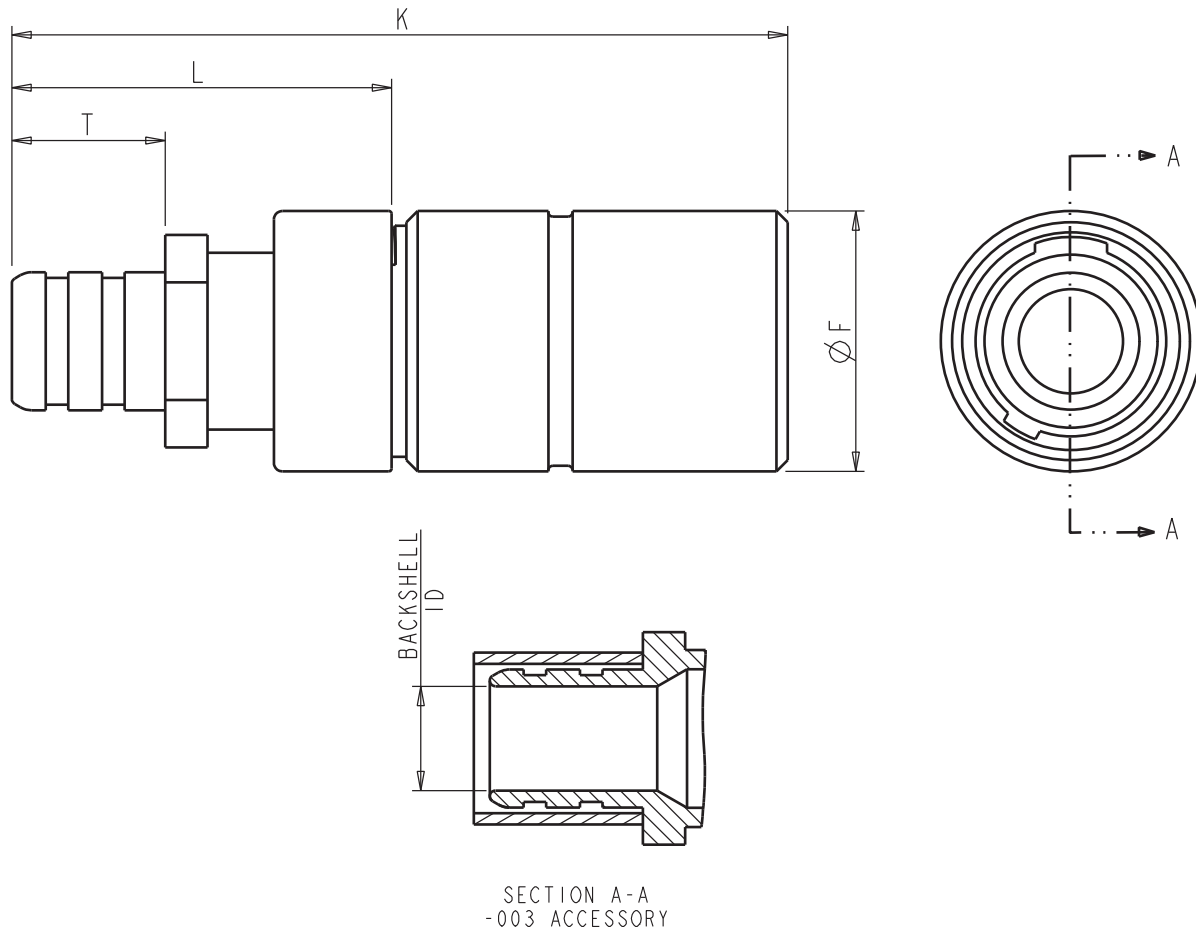

Shell Size	ØF	K	L	T	Backshell ID
					-003
Size 06	.462 (11.73)	1.377 (34.98)	.674 (17.12)	.272 (6.91)	.185 (4.70)
Size 07	.575 (14.61)	1.377 (34.98)	.674 (17.12)	.272 (6.91)	.265 (6.73)
Size 08	.620 (15.75)	1.377 (34.98)	.674 (17.12)	.272 (6.91)	.345 (8.76)
Size 09	.690 (17.53)	1.447 (36.75)	.674 (17.12)	.272 (6.91)	.425 (10.80)
Size 10	.760 (19.30)	1.447 (36.75)	.674 (17.12)	.272 (6.91)	.505 (12.83)

All dimensions are in inches (mm shown in brackets) and are for reference only. Figure enlarged scale.

Receptacle

SCE2-X-L1TXX-XXPX-003

- Inline Latching Receptacle, Threaded Backshell

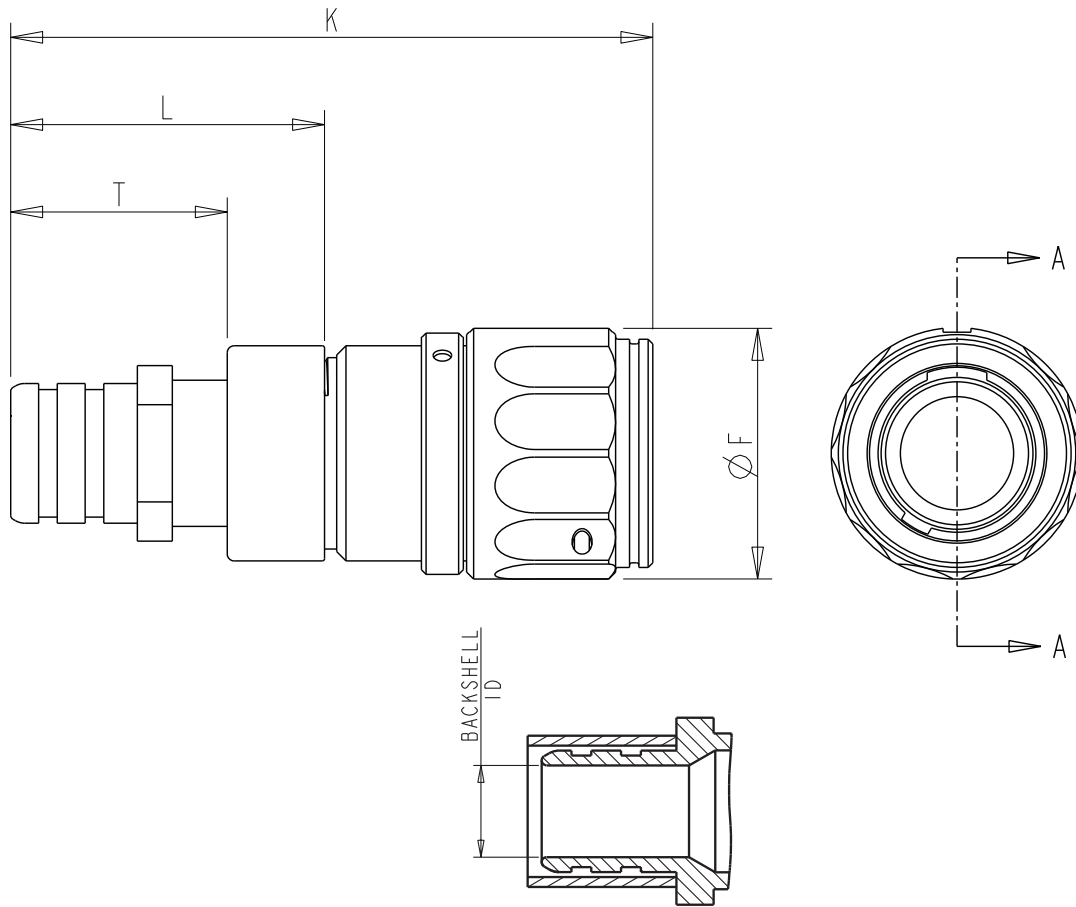

SECTION A-A
-003 ACCESSORY

Shell Size	ØF	K	L	T	Backshell ID
					-003
Size 06	.538 (13.67)	1.379 (35.03)	.674 (17.12)	.465 (11.81)	.185 (4.70)
Size 07	.610 (15.50)	1.379 (35.03)	.674 (17.12)	.465 (11.81)	.265 (6.73)
Size 08	.699 (17.75)	1.379 (35.03)	.674 (17.12)	.465 (11.81)	.345 (8.76)
Size 09	.770 (19.56)	1.449 (36.80)	.674 (17.12)	.465 (11.81)	.425 (10.80)
Size 10	.840 (21.34)	1.449 (36.80)	.674 (17.12)	.465 (11.81)	.505 (12.83)

All dimensions are in inches (mm shown in brackets) and are for reference only. Figure enlarged scale.

Receptacle

SCE2-X-07AXX-XXPX-XXX

- Rear Mount Jam Nut Receptacle



Receptacle

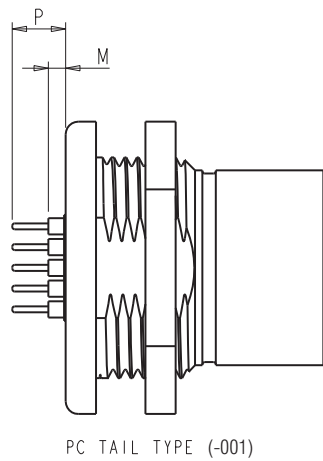
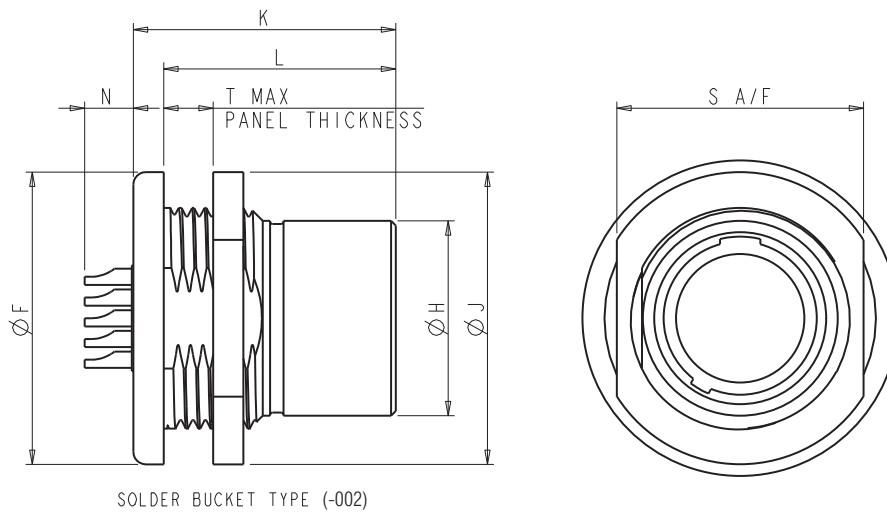

Shell Size	ØF	ØH	ØJ	K	L	M	N	P	S A/F	T Max
Size 06	.750 (19.05)	.462 (11.73)	.750 (19.05)	.835 (21.21)	.738 (18.75)	.055 (1.40)	.155 (3.94)	.170 (4.42)	.672 (17.07)	.157 (4.45)
Size 07	.895 (22.73)	.575 (14.61)	.895 (22.73)	.835 (21.21)	.738 (18.75)	.055 (1.40)	.155 (3.94)	.170 (4.42)	.750 (19.05)	.157 (4.45)
Size 08	.930 (23.62)	.620 (15.75)	.930 (23.62)	.835 (21.21)	.738 (18.75)	.055 (1.40)	.155 (3.94)	.170 (4.42)	.825 (20.96)	.157 (4.45)
Size 09	1.005 (25.53)	.690 (17.53)	1.005 (25.53)	.905 (22.99)	.808 (20.52)	N/A	.080 (2.03)	.170 (4.42)	.900 (22.86)	.157 (4.45)
Size 10	1.080 (27.43)	.760 (19.30)	1.080 (27.43)	.905 (22.99)	.808 (20.52)	N/A	.080 (2.03)	.170 (4.42)	.975 (24.77)	.157 (4.45)

All dimensions are in inches (mm shown in brackets) and are for reference only. Figure enlarged scale.

Receptacle

SCE2-X-71AXX-XXPX-XXX

- Front Mount Receptacle, Threaded

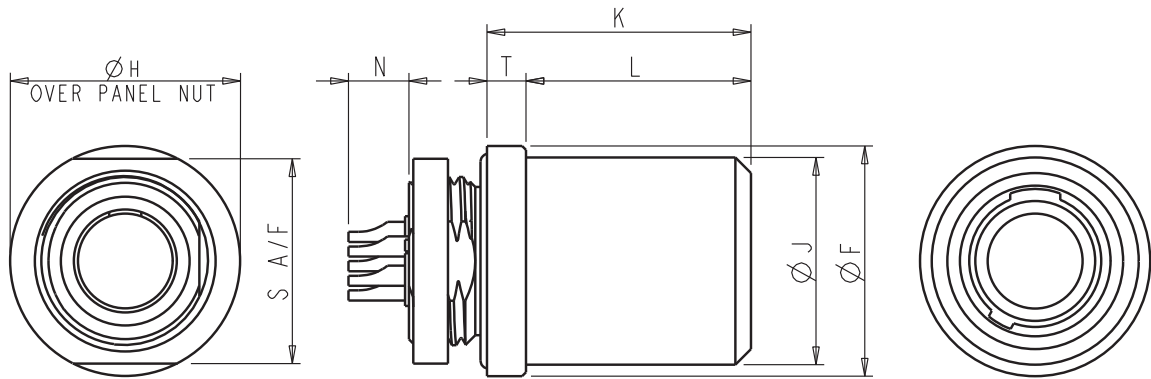

SOLDER BUCKET TYPE (-002)

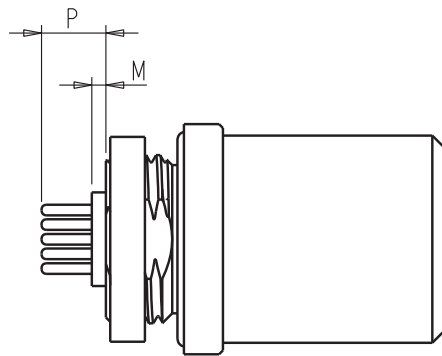

PC TAIL TYPE (-001)

Shell Size	ØF	ØJ	ØH	K	L	M	N	P	S A/F	T
Size 06	.590 (14.99)	.462 (11.73)	.590 (14.99)	.877 (22.28)	.677 (17.20)	.015 (0.38)	.113 (2.87)	.130 (3.30)	.525 (13.34)	.100 (2.54)
Size 07	.620 (15.75)	.575 (14.61)	.620 (15.75)	.877 (22.28)	.677 (17.20)	.015 (0.38)	.113 (2.87)	.130 (3.30)	.685 (17.40)	.100 (2.54)
Size 08	.760 (19.30)	.620 (15.75)	.760 (19.30)	.877 (22.28)	.677 (17.20)	.015 (0.38)	.113 (2.87)	.130 (3.30)	.825 (20.96)	.100 (2.54)
Size 09	.890 (22.61)	.690 (17.53)	.890 (22.61)	.947 (24.05)	.747 (18.97)	N/A	.113 (2.87)	.060 (1.52)	.955 (24.26)	.100 (2.54)
Size 10	.930 (20.62)	.760 (19.30)	.930 (20.62)	.947 (24.05)	.747 (18.97)	N/A	.113 (2.87)	.060 (1.52)	.995 (25.27)	.100 (2.54)

All dimensions are in inches (mm shown in brackets) and are for reference only. Figure enlarged scale.

Accessories

390-5057-XX-XXX-XX

- Metal Dust Cap Assembly for Plugs

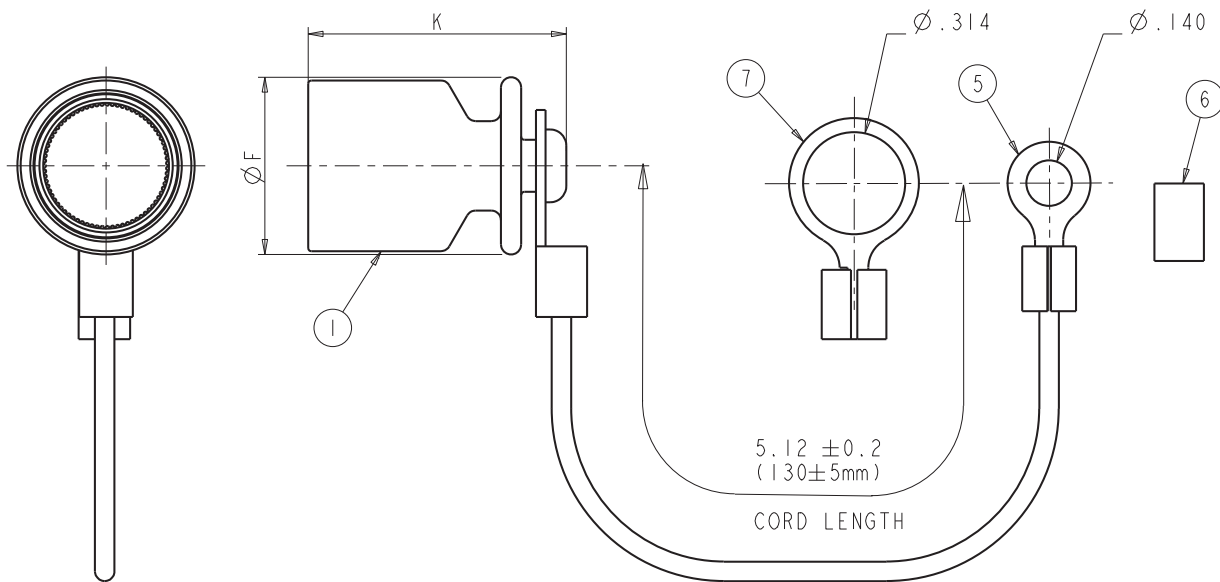

Shell size	Part number	Item 1 Cap	
		ØF	K
06	390-5057-06-XXX-XX	.464 (11.79)	.794 (20.17)
07	390-5057-07-XXX-XX	.545 (13.84)	.794 (20.17)
08	390-5057-08-XXX-XX	.620 (15.75)	.794 (20.17)
09	390-5057-09-XXX-XX	.695 (17.65)	.794 (20.17)
10	390-5057-10-XXX-XX	.770 (19.56)	.794 (20.17)

Supplied with			
Part number	Item 5 Eyelet	Item 6 Crimp ferrule	Item 7 Large eyelet
390-5057-XXX-XX-01	–	–	–
390-5057-XXX-XX-02	–	1	–
390-5057-XXX-XX-03	1	–	–
390-5057-XXX-XX-04	1	1	–
390-5057-XXX-XX-05	–	–	1

All dimensions are in inches (mm shown in brackets) and are for reference only. Figure enlarged scale.

Accessories

390-5056-XX-XXX-XX

- Metal Dust Cap Assembly for Receptacles

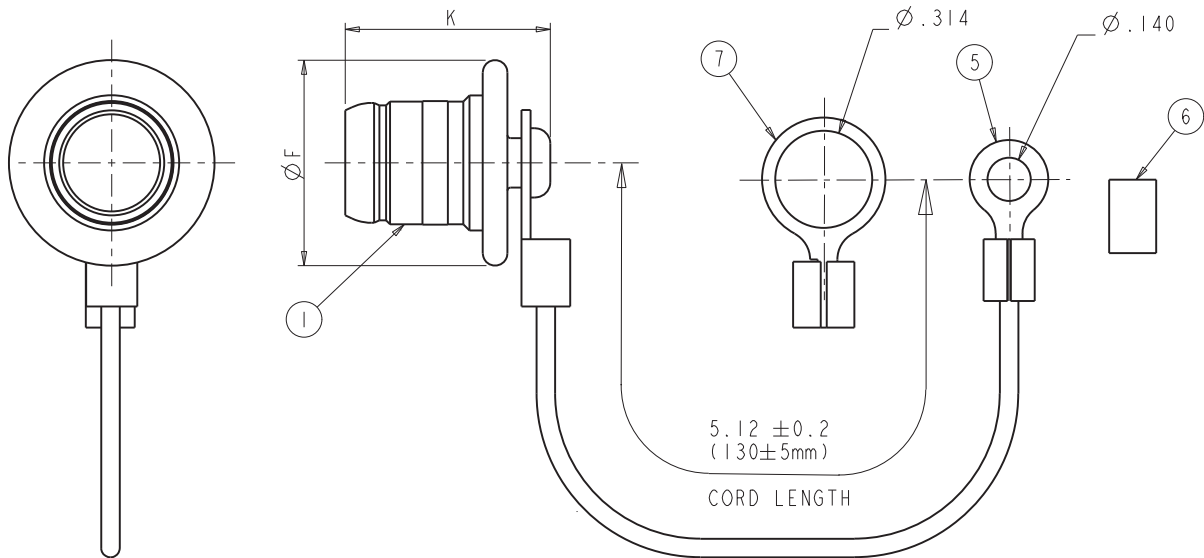

Shell size	Part number	Item 1 Cap	
		ØF	K
06	390-5056-06-XXX-XX	.575 (14.61)	.664 (16.87)
07	390-5056-07-XXX-XX	.575 (14.61)	.664 (16.87)
08	390-5056-08-XXX-XX	.750 (19.05)	.664 (16.87)
09	390-5056-09-XXX-XX	.825 (20.95)	.664 (16.87)
10	390-5056-10-XXX-XX	.900 (22.86)	.664 (16.87)

Supplied with			
Part number	Item 5 Eyelet	Item 6 Crimp ferrule	Item 7 Large eyelet
390-5056-XXX-XX-01	–	–	–
390-5056-XXX-XX-02	–	1	–
390-5056-XXX-XX-03	1	–	–
390-5056-XXX-XX-04	1	1	–
390-5056-XXX-XX-05	–	–	1

All dimensions are in inches (mm shown in brackets) and are for reference only. Figure enlarged scale.

Accessories

390-5064-XX-XXX-XX

- Rubber Dust Cap Assembly for Plugs

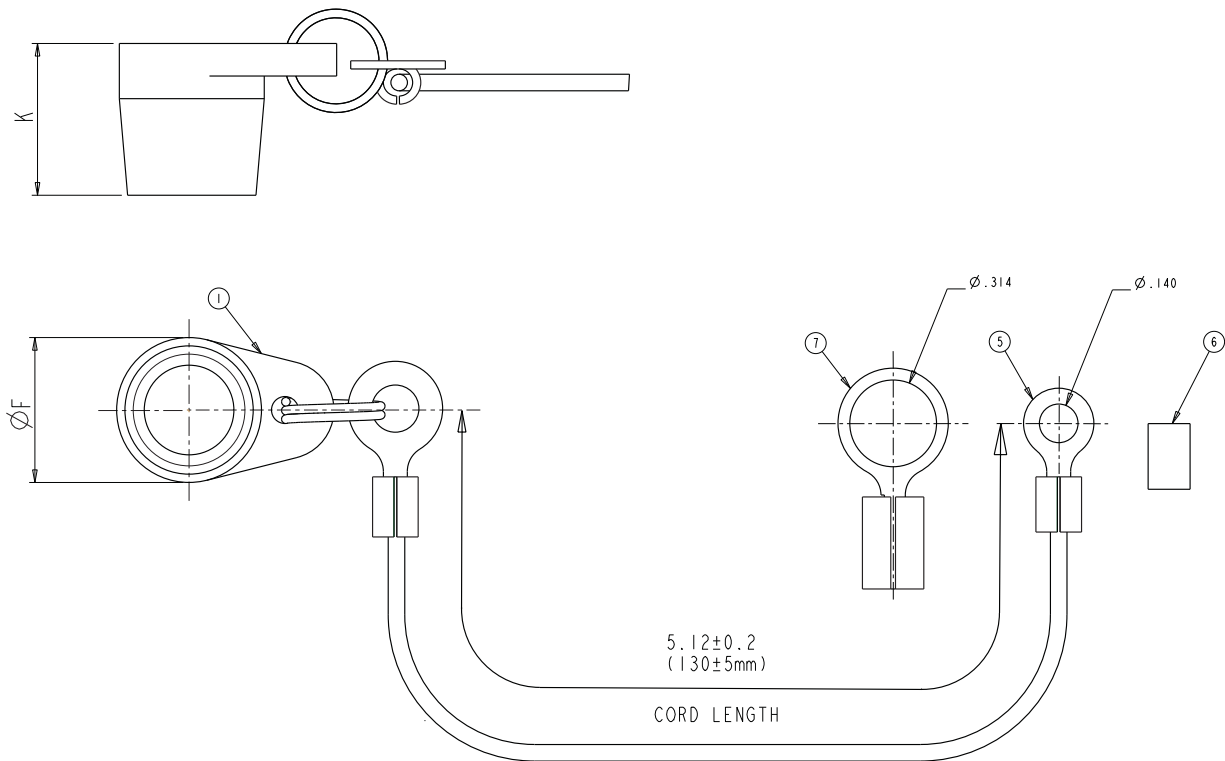

Shell size	Part number	Item 1 Cap	
		ØF	K
06	390-5064-06-XXX-XX	.450 (11.43)	.550 (13.97)
07	390-5064-07-XXX-XX	.525 (13.34)	.550 (13.97)
08	390-5064-08-XXX-XX	.595 (15.11)	.550 (13.97)
09	390-5064-09-XXX-XX	.665 (16.89)	.550 (13.97)
10	390-5064-10-XXX-XX	.735 (18.67)	.550 (13.97)

Supplied with			
Part number	Item 5 Eyelet	Item 6 Crimp ferrule	Item 7 Large eyelet
390-5064-XXX-XX-01	–	–	–
390-5064-XXX-XX-02	–	1	–
390-5064-XXX-XX-03	1	–	–
390-5064-XXX-XX-04	1	1	–
390-5064-XXX-XX-05	–	–	1

All dimensions are in inches (mm shown in brackets) and are for reference only. Figure enlarged scale.

Accessories

390-5063-XX-XXX-XX

- Rubber Dust Cap Assembly for Receptacles

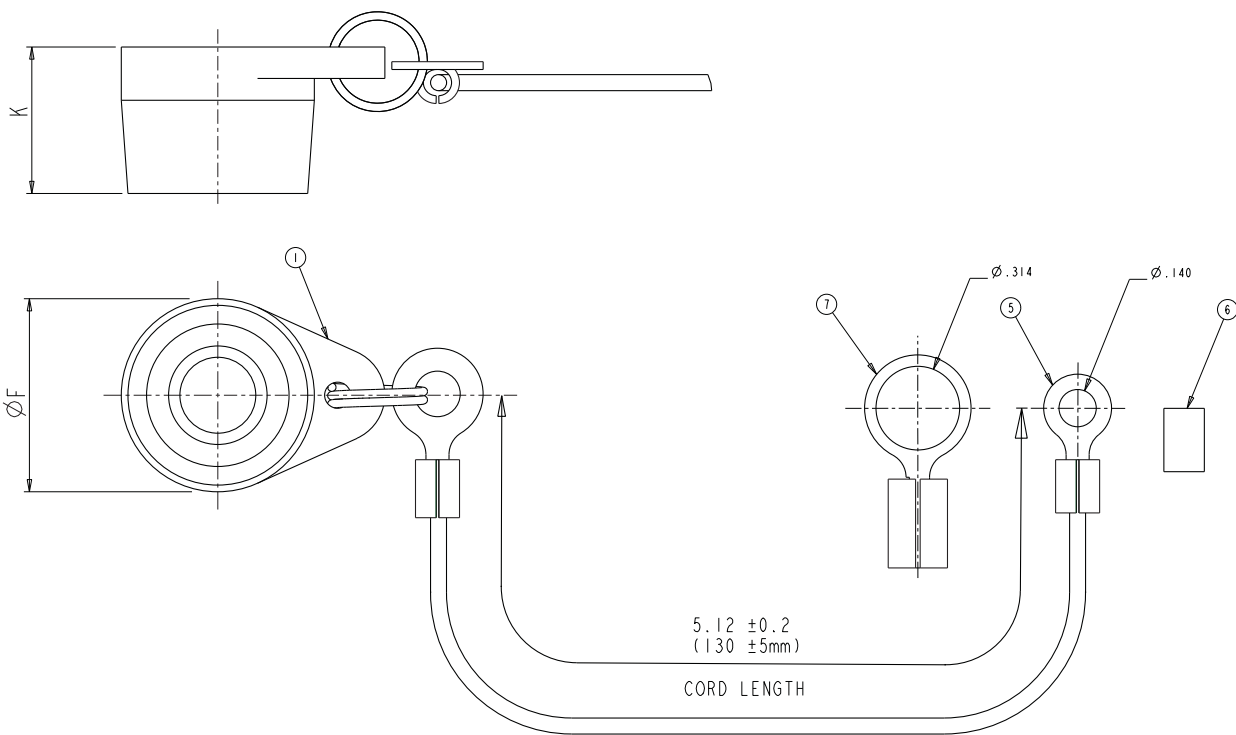

Shell size	Part number	Item 1 Cap	
		ØF	K
06	390-5063-06-XXX-XX	.450 (11.43)	.550 (13.97)
07	390-5063-07-XXX-XX	.525 (13.34)	.550 (13.97)
08	390-5063-08-XXX-XX	.595 (15.11)	.550 (13.97)
09	390-5063-09-XXX-XX	.665 (16.89)	.550 (13.97)
10	390-5063-10-XXX-XX	.735 (18.67)	.550 (13.97)

Supplied with			
Part number	Item 5 Eyelet	Item 6 Crimp ferrule	Item 7 Large eyelet
390-5063-XXX-XX-01	–	–	–
390-5063-XXX-XX-02	–	1	–
390-5063-XXX-XX-03	1	–	–
390-5063-XXX-XX-04	1	1	–
390-5063-XXX-XX-05	–	–	1

All dimensions are in inches (mm shown in brackets) and are for reference only. Figure enlarged scale.

Accessories

HEATSHRINK BOOTS

- Part number: 123GB-0798-XX-X-0
XX = shell size, for example: 06, 07, 08, 09, or 10
X = S for straight or R for right angled



BRAID RETENTION STRAP

- Part number: 123GB-0799-0
Tooling available on request



CASTELLATED PANEL NUT

- Add deviation (981)
Tooling available on request



Overmoulded cable harnesses using Terrapin connectors



Amphenol Ltd design, prototype and manufacture a wide range of both standard and customised cable harness assemblies utilising overmould technology. The Terrapin connector range has been designed specifically to lend itself to this method of termination.

Amphenol Ltd's capability in manufacturing is matched by our engineering expertise, we are able to offer a full design and development service from drawing conception to production delivery.

Overmoulding has fast become widely recognised for the benefits it brings to equipments used in both Military and Harsh Environment situations.

Military and harsh environment situations

- Both Standard and Custom profile mouldings available
- In-house design and prototype facility
- Aesthetically uniform product
- Repeatable high complexity mouldings
- Low cost and repair by replacement
- Robust and tamper-proof
- Straight and angled mouldings
- Low profile mouldings
- Finger grips, logos and tactile indicators optional
- Mould material suitable for NBC washdown
- High degree of sealing – IP68

Typical applications

- | | |
|----------------------------|---------------------------------|
| • Chemical detection units | • Radios |
| • Comms units | • Routers |
| • Display Modules | • Ruggedised laptops |
| • GPS | • Sensor units |
| • Headsets | • Surveillance and rangefinders |
| • Hubs | • Weapons systems |
| • LAN Switches | |

Notes

Notes

Products are sold subject to Amphenol's conditions of sale ("the standard conditions"). All specifications and statements contained herein are believed to be correct at the time of printing, but no representation or warranty, express or implied, is given as to any specification or statement contained herein. Product specifications including performance characteristics are typical only and subject to deviation. Specifications are also subject to change without notice. Users should not assume that all safety measures are indicated or that other measures may not be required. No representation or warranty, express or implied, is given that any use of products (including any stated or suggested use) does not infringe any patent, registered design or other third party rights and no stated or suggested use of products can be taken to recommend any such infringement.

Amphenol®

For more information call **+44 (0)1227 773200**

Amphenol Ltd Thanet Way Whitstable Kent CT5 3JF | Email: terrapin@amphenol.co.uk | www.amphenol.co.uk

JUNE 2010